

Automated Flood Monitoring System Using Wireless Sensor Network

Dr.S.Joshua Kumaresan

Associate Professor, Dept of ECE, R.M.K. Engineering College, Kavaraipettai, Tamilnadu, India.

A.Parthiban

Student, Dept of ECE, R.M.K. Engineering College, Kavaraipettai, Tamilnadu, India

Perumakuppam Mukesh

Student, Dept of ECE, R.M.K. Engineering College, Kavaraipettai, Tamilnadu, India

M.Prem

Student, Dept of ECE, R.M.K. Engineering College, Kavaraipettai, Tamilnadu, India

P.Kamaraj

Scientist/Engineer-SE, National Atmospheric Research Laboratory, Tirupathi, Andhra Pradesh, India

Abstract - Basically “flood” is a large quantity of water covering an area that is usually dry. Flood may occur as a result of: a heavy rainfall, a river flowed over its banks, a burst of water pipes, etc. Hazards caused due to flood are the most destructive and common of all natural disasters. Flood is a natural calamity we cannot stop the flood but we can control and manage before it occurs. Flood disasters cause loss of lives and property every year. So it devastates on the social and economic conditions of the people. Before Every year, 25 million people living in coastal areas of Tamilnadu are affected and devastated by floods. Flood occurred in north Gujarat in July 2015 due to heavy rain and more than 70 villages got affected. In Nov-Dec 2015, Adyar, Cooum Rivers got flooded due to the heavy rain in Chennai, Tamil Nadu which caused loss of human lives besides economic loss. Frankly speaking, commercial buildings, public goods, homes, pastural and agricultural lands and other physical properties will get damaged due to flood.. Health sector is not exempted because there are always risks to safety and health during and after floods. Floodwaters usually have bacteria that causes diseases, animal and human waste and also dirty oil.

Index Terms - Auto Chemical mixer, Agricultural Sprayers

INTRODUCTION

An overflow of water on dry ground is defined as flood. This usually occurs because of heavy rainfall, a river that overflows, melting of snow or broken dam. Tsunamis and storm surge also cause floods but their occurrence is rare. In 1931, Twenty lakh to forty lakh people were killed in china due to heavy flood. A river and an obstruction like buildings in the pathway for free flow of rain water increases the risk of flood in an area. Depends on vulnerability and exposure, the consequences of flood may be severe. In this paper, we are trying to identify the flood risk and hence monitor the flood. In our flood monitoring system we have transmitter and receiver. In transmitter both seismic and humidity sensors are present. Once the flood risk is identified it will send to the user by the buzzer. Seismic sensor is used to identify the vibration and

humidity sensor is used to identify the water-level and density. Finally in receiver part we are identifying the detected risk.

EXISTING METHOD

In existing system, Telecommunications system like cell, phone, media, social network are used to alert the people about the disaster information. But due to disaster the network also affected due to natural calamities like flood, cyclone, heavy rains. So the GSM based alert system are not reliable.

PROPOSED SYSTEM

In our proposed system, Radio Frequencies (RF) and IOT are used to communicate the info to other this is low cost and not dependent on cell phone towers. So our system is more reliable than other systems during natural calamities.

LITERATURE REVIEW

This project is focuses on detecting and giving early warning alert of flood to the people. For this project we referred some IEEE papers and description about that is given below M. Janssen [1] in his paper, Serious Gaming within the Dutch flood risk management – the MLS game, deals with delta programme of Netherlands. Netherlands introduced Delta Programme that planned to take safety measure for fresh water supply and to predict the floods by predicting the climate change. This programme is aiming to avoid a terrible flood by predicting before the event occurs. The Delta Programme prepares a framework of policies regarding development of urban areas with flood proof system, updating standards for protection from flood and improving systems for better management of disasters. Maximum flexibility in planning is required to tackle population growth, dwindling economy and uncertain climatic conditions. We need to keep options open and change the plans whenever necessary. These steps that align with nature will increase the livability conditions in urban areas. This multi-governmental process is directed by the Delta Commissioner. He takes required steps for all the problems and submits annual report to parliament about the progress. To stabilize the finance, 1 billion EURO is allotted as delta fund every year from 2020 onwards. This delta

programme, the huge fund and the commissioner himself are bounded by the new Delta Act.

C. D. van Borkulo, et al [2] deals with a new method for constructing networks from binary data. Nowadays network analysis is applied in the field of educational sciences and psychology where networks structures are not used before. Network structure assessment is a major step while applying network models. Existing methods either applicable only for Gaussian data or have serious disadvantages. In this paper, they presented a method for network structures assessment from binary data. Usually binary data models have more computational complexity. But in this paper the authors presented a computationally effective model for assessing network structures. This is developed on the basis of Ising models that is applied in physics. This methodology combines selecting a model depending on a Goodness-of-Fit measure with logistic regression to find appropriate relations between variables which describe connections of network. This method reveals the appropriate features of a network for considerably large sample sizes and is confirmed by validation study also. The proposed model is applied to 1108 people to assess the network of anxiety and depression. Future extensions of the model that are possible are discussed in detail.

HARDWARE DESCRIPTION

A. PIC 16F877A

A PIC microcontroller has three axes and SPI/I2C digital interface. It consists of two programmable and flexible interrupt request outputs and innovative functionalities embedded within it. Timing and thresholds of interrupt signals can be programmed. PIC 16F877A consumes less than 1mW power and requires 2.16V to 3.6V. It has high pass filter and self-test embedded within the chip. It can operate in the temperature that ranges from -40°C to +85°C. It is 40 pin IC with 5 ports namely Port A to Port E. It has inbuilt flash/ROM program memory, RAM and EEPROM data memory.

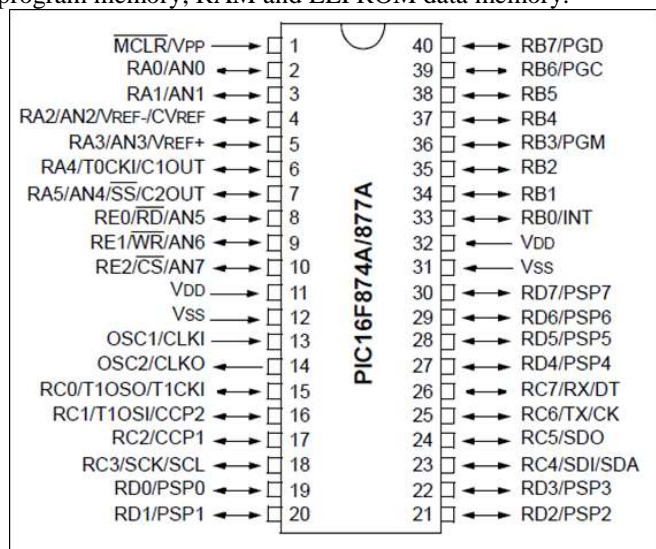

FIG. 1. PIN LAYOUT OF PIC16F877A

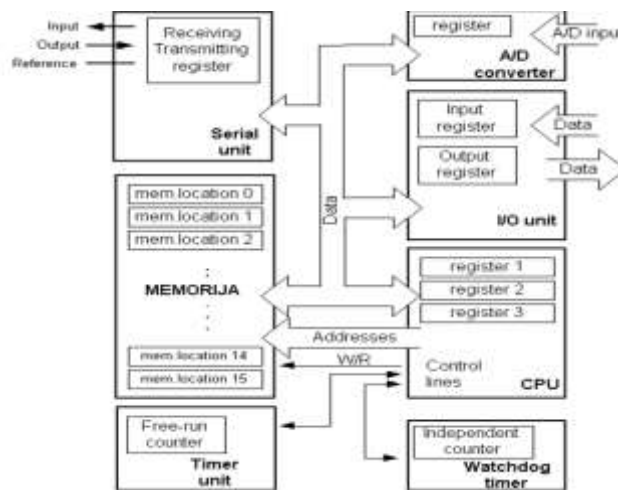

FIG. 2. BLOCK REPRESENTATION OF THE MICROCONTROLLER

B. VIBRATIONAL SENSOR

Synthetic piezoelectric ceramics and quartz are widely used piezoelectric materials in vibration sensors nowadays. These two are sufficient to design a good vibration sensor. Design flexibility is possible because of variations in their properties. Piezoelectric natural quartz materials has inferior charge sensitivity than piezoceramic materials that are artificially made. Piezoceramic materials that are specially made for sensor applications are widely used in vibration sensors now days. Even in extreme and unsafe environments, accurate data can be obtained by tailored materials. Piezoceramic material has very high output sensitivity than quartz and so the modern sensors can be designed with good frequency response.

C. HUMIDITY SENSOR

A thin strip of metal oxide is placed between two electrodes in a capacitive humidity sensor to measure relative humidity. As atmosphere's relative humidity changes, the electrical capacity of the metal oxide also changes. Major application areas of humidity sensor are Weather, commercial and industries. Relative humidity from 0% to 100% can be measured using capacitive type sensors as they are linear. Regular calibration and complex electronic circuits are required to get good accuracy. Since these sensors measures accurately, the designers are using this widely in process and atmospheric measurements. These are capable of measuring the maximum range of relative humidity even to zero percent relative humidity. No active temperature compensation is required over wide temperature ranges because of this low temperature effect.

D. CRYSTAL OSCILLATOR

The mechanical resonance of a vibrating crystal of piezoelectric material is used to create a very precise frequency electrical signal in a crystal oscillator. This accurate frequency is used to provide stable frequencies for radio receivers or transmitters and stabilizes clock signal for digital integrated circuits.

E. INTERNET OF THINGS

Unique identifiers are provided to people, animals or objects in **Internet of Things (IOT)** environment. It can also able to transfer data over a network without the need of person-to-computer or person-to-person interaction. The Internet of Things (IoT) board has a controller to process all input GPRS based online data and UART data and also equipped with

SIM900 GPRS modem to enable internet connection. In IoT environment, data can be uploaded to a social network or a specific site. Then this data can be retrieved by user at a later time.

F. UART

UART is the acronym for Universal Asynchronous Receiver Transmitter. UART is a hardware device in a computer which is used for asynchronous serial communication. In asynchronous transmission, UART transmits first a "start" bit, then five to eight data bits with LSB first, a "parity" bit that is optional, and then one, one and a half, or two "stop" bits. In this type of communication, the speed of transmission and data format can be configured. It is used for transmitting and receiving data. UART applications include Bluetooth modules, GPS receivers, RFID based applications, wireless communication systems, GSM and GPRS modems.

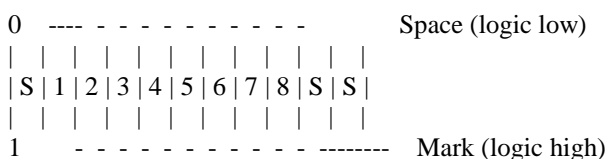

Asynchronous data Format

The first bit to be transmitted always is the right-most bit. The parity bit will be following the data bits (if parity bit is present), before the stop bit(s).

BLOCK DIAGRAM

NODE 1

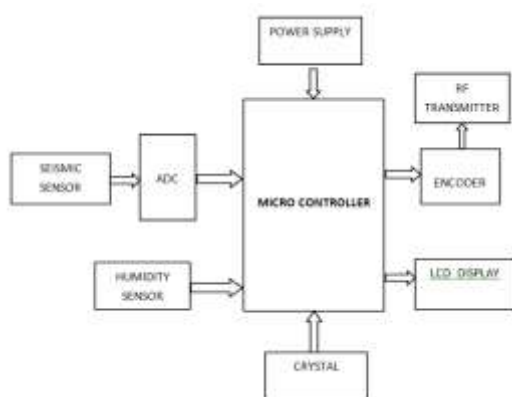

FIG. 3. BLOCK DIAGRAM OF NODE 1

NODE 2

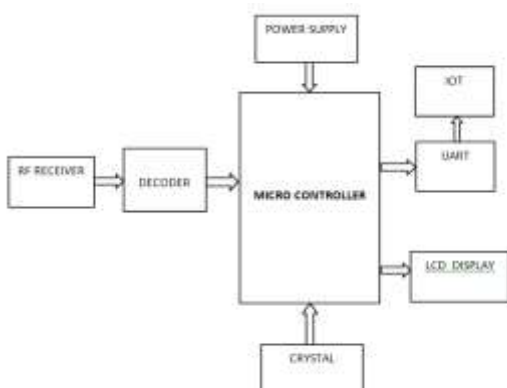

FIG. 4. BLOCK DIAGRAM OF NODE 2

G. LCD DISPLAY

LCD (liquid crystal display) is an optical device modulated electronically which uses the light controlling properties of liquid crystals that are combined along with polarizers. Liquid crystals use a reflector or backlight to emit images in monochrome or color.

Steps for Interfacing LCD with PIC Microcontroller

STEP 1 : Classification : LCD are available in many types that are specified in the format AxB (16x1, 16x2, 20x2) where A (characters) represents the number of columns and B (lines) represents the number of Rows.

STEP 2: Connection: Standard Hitachi Pin out is followed in almost all LCD. But few LCD's may not contain pins 15 & 16 so it can be wired as shown in figure below.

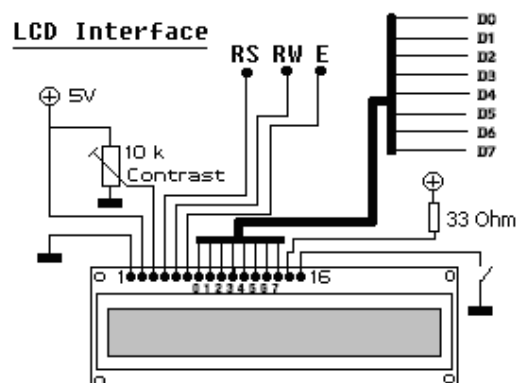

FIG. 5. LCD INTERFACE

STEP 3 : Interfacing : Connect pins D0 - D7 RS, E, RW of LCD to pins of the PIC micro controller. For example, Data bus can be connected to port A and the pins E, RS, RW to port B. LCD can also be used in Nibble Mode (4 data pins) to save pins. RW line can also be permanently grounded. (always in write mode). LCD has few standard commands to switch On. Clear display screen, Return home, Shift cursor position to left, are some of the commands that are used.

H. ENCODER

A device that converts or translates the data or information from one format to another format (binary format such as 1 and 0).

I. DECODER

Decoder is used to reverse the operation of encoder and recover the original information from coded information.

J. RF TRANSMITTER AND RECEIVER

For applications that require short-range RF remote controls, TWS-434 and RWS-434 can be used which are extremely small. In an outdoor area, in 400 foot range, at 433.92MHz frequency the TWS-434 transmitter gives an output of up to 8mW. The range 200 foot approximately in indoors and can penetrate through most walls. This transmitter operates in a voltage range of 1.5 to 12 Volts-DC and can accept both digital and analog inputs. Thus a small handy RF transmitter can be built very easily using this TWS-434. The approximate size of TWS-434 is just one third as that of a postage stamp.

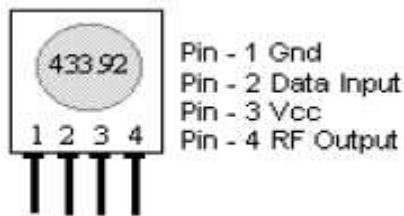

FIG. 6. TWS-434 PIN DIAGRAM

The RWS-434 receiver has a sensitivity of $3\mu\text{V}$ and operates at a frequency of 433.92MHz. The receiver operates in a DC voltage range of 4.5 to 5.5 volts and has both digital and analog outputs.

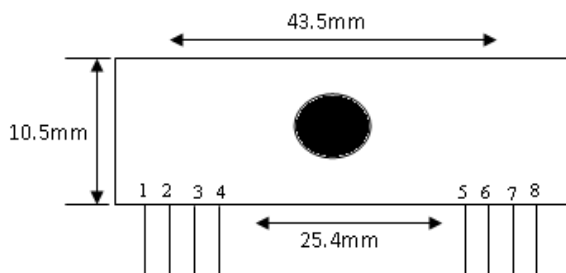

FIG. 7. RWS-434 PIN DIAGRAM

K. POWER SUPPLY

The power supply section consists of a transformer, a bridge circuit, a filter and a regulator. The stepdown transformer is used to convert 230v ac to 12v ac. The bridge rectifier circuit converts ac to pulsating dc. The bridge rectifier circuit consists of four diodes connected to create a bridge structure. The input ac voltage is given to the diagonally opposite ends of the bridge. The load is coupled between the remaining two ends of the bridge. The filter is used to remove the ripples in the supply. The filter output remains constant as long as the input voltage and output load resistance is maintained constant. But if either input voltage or load varies, then the voltage from the filter changes. Therefore a voltage regulator is necessary at the final output stage.

The regulator makes the supply voltage constant. A constant output voltage can be obtained from a power supply irrespective of variations in input voltage. For small loads less than 7 amperes, constant three-terminal linear regulators are used. It can generate constant bipolar voltages of 3V, 5V, 9V, 12V, or 15 V. Positive voltages are regulated by the "78xx" series (7805, 7812, etc.) whereas the negative voltages are regulated by "79xx" series (7905, 7912, etc.). Mostly, the output voltage is represented in the final two digits of the device number. For example, the device number 7805 denotes a +5 V regulator and the device number 7915 denotes a -15 V regulator. Depends on the model, the 78xx series ICs can provide a maximum of 1.5 Amperes. This three terminal voltage regulators can provide current output up to a maximum 1A. The available output voltages are in the range of 5, 6, 8, 9, 10, 12, 15, 18, 24 volts. This regulator protects the circuit against thermal overload and short circuit. This also protects the transistor to operate within safe operating area.

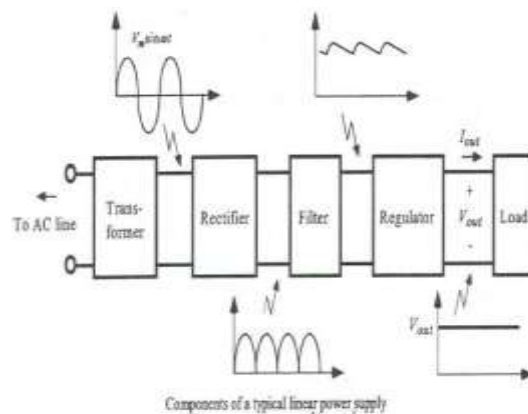

FIG. 8. COMPONENTS OF A TYPICAL LINEAR POWER SUPPLY

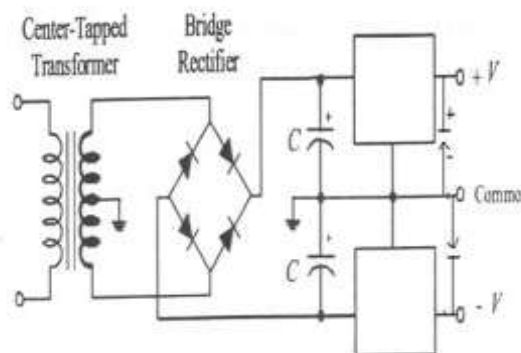

FIG. 9. THE BASIC POWER SUPPLY SCHEMATIC

L. BUZZER

A device that produces sound when audio signals are given to it, is called a buzzer. DC voltage is required to operate a buzzer. The applications of buzzer include computers, alarms, printers and other electronic products as sound devices.

EMBEDDED C:

Embedded C is related with a specific hardware architecture and is written in programming language such as C. C language along with few additional header files is Embedded C. These header files may vary from one controller to another. Embedded C is just the extension of C language and not much different from C. The source code format depends upon the type of microprocessor or microcontroller used. High level optimization can done through embedded C. It is widely applied in microcontroller based and microprocessor based applications. The embedded system has only few memory locations and thus the resources are limited. In embedded c output is not available at operating system as constraints run on real time. Only pre-defined program can be run in embedded c.

RESULT

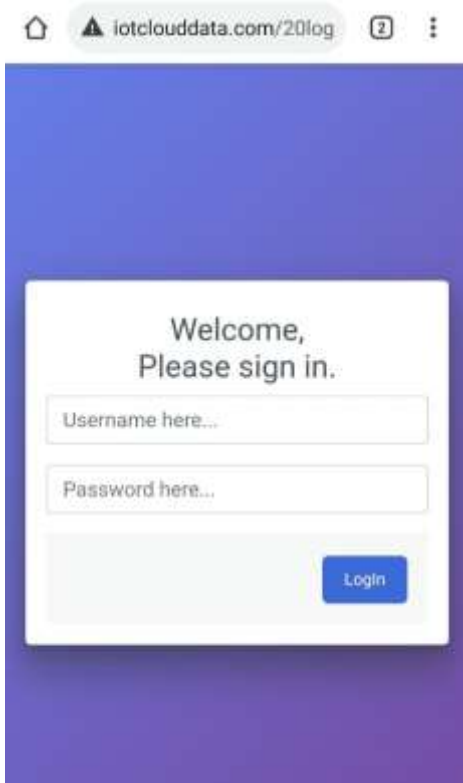

FIG. 10. USERLOGINPAGE

Above login page is for both desktop/laptop and android application users who can login using the details of username and password.

LogID	DATA	LogDate	LogTime
69	@@@@@Vibration_@@@Seismic@@@Humidity_@@@RF@@@Humidity_@@@RF@@@Humidity_@@@RF@@@	08/19/2021	08:16:16
87	@@_Humidity_@@@RF@@@Humidity_@@@RF@@@Humidity_@@@RF@@@	08/19/2021	08:20:22
89	@@Water_@@@Seismic@@@	08/19/2021	08:20:26
91	@@_Humidity_@@@RF@@@	08/19/2021	08:22:27
92	@@Water_@@@Seismic@@@	08/19/2021	08:23:40
93	@@Water_@@@Seismic@@@Vibration_@@@Seismic@@@Vibration_@@@Seismic@@@Vibration_@@@Seismic@@@Vibration_@@@Seismic@@@	08/19/2021	08:23:54
94	@@Water_@@@Seismic@@@	08/19/2021	08:23:57
95	@@Water_@@@Seismic@@@Humidity_@@@RF@@@Vibration_@@@Seismic@@@Humidity_@@@RF@@@Water	08/23/2021	11:50:08
99	@@Water_@@@Seismic@@@Vibration_@@@Seismic@@@	08/23/2021	11:58:03
100	@@Water_@@@Seismic@@@Vibration_@@@Seismic@@@	08/23/2021	11:58:06

FIG. 11. DATA DISPLAY PAGE

The data collected from sensors are displayed as shown in above figure. This data displays time of occurrence, date of occurrence and disaster details.

ADVANTAGES

- By this project we can save the life of humans as well as living beings. We can also preserve and conserve the water.
- We can monitor the flood automatically during rainy seasons.
- We can also able to reduce the consumption of over use of water.
- By this project we can able to timely detection of possible flood risks and floods.

HARDWARE IMPLEMENTATION

Copyrights @Kalahari Journals

A. NODE 1

The NODE 1 is a transmitter part where it acts as a master circuit. It consists of Microcontroller, Seismic sensor, Humidity sensor, Crystal oscillator, LCD display, RF transmitter. Power supply is given to the main controlling unit microcontroller. Seismic sensor is used to detect the vibration and also used to measure the ground motion when it is shaken by a perturbation. Encoder is used to transmit the data from RF transmitter to microcontroller.

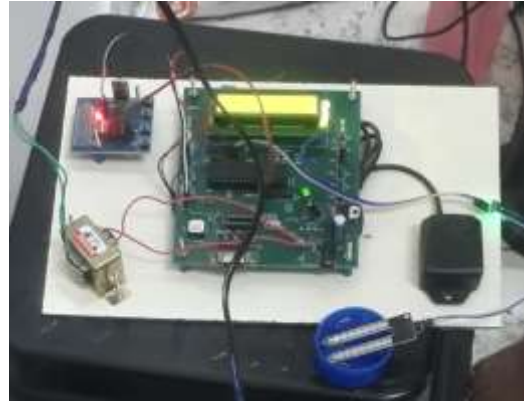

FIG. 12. FLOOD MONITORING ELECTRICAL CIRCUIT NODE 1

B. NODE 2

The NODE 2 is a receiver part where it acts as a slave circuit. It consists of microcontroller, RF receiver, UART, LCD display, crystal oscillator, Buzzer. Power supply is given to microcontroller. UART is used for transmitting and receiving data. Decoder is used to transmit the data from RF receiver to microcontroller. Buzzer is used as an indicator when the sensor detects.

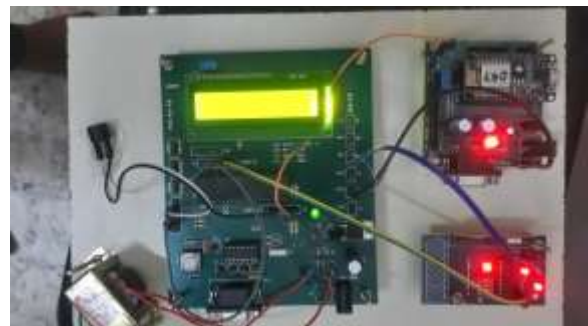

FIG. 13. FLOOD MONITORING ELECTRICAL CIRCUIT NODE 2

CONCLUSION

Automated flood monitoring system using wireless sensor node is designed to reduce the loss of precious human lives whenever there is threat of flood. This system is designed to give alert signals to civilians through warning sounds who are nearby and also send warning signals to people in long distance. As India faced devastating flood in Chennai, there arise a need of efficient flood monitoring systems. The proposed system will be efficient because it has better coordination of monitoring, and transmission technologies.

REFERENCES

[1]. M. Jansen, "Serious Gaming Within the Dutch flood risk management – the MLS game," University of Twente, 2012.

- [2]. S. Epskamp, A. O. J. Cramer, L. J. Waldrop, V. D. Schmittmann, D. Borsboom. "Qgraph: Network visualisation of relationships in psychometric data". *Journal of Statistical Software*, vol.48, pp.1-18, 2012.
- [3]. C.D. van Borkulo, D. Borsboom, S. Epskamp, T. F. Blanken, L. Boschloo, R. A. Schoevers, L. J. Waldrop,"A new method for constructing networks from binary data".*Scientific Reports*,4:5918,2014 .
- [4]. Q. Zhou, I. Mayer, G. Bekebrede, J. Warmerdam, M. Knepfle. "Integrating Water management and Spatial Planning through Serious gaming". *The water game in the Netherlands. Water Game_NIG-annual_qiqi_2013*.
- [5]. H. G. K. Hummel, J. van Houcke, R. J. Nadolski, T. van der Hiele, H. Kurvers, A. Lohr, "Scripted collaboration in serious gaming for complex learning: Effects of multiple perspectives when acquiring water management skills", *British Journal of Education Technology*, 2010.
- [6]. M. Imran, S. Elbassouni, C. Castillo, F. Diaz, P. Meier, "Extracting information Nuggets from Disaster-Related Messages in Social Media," in proceedings of the 10th International Conference on Information Systems for Crisis Response and Management ISCRAM2013, Vancouver.
- [7]. S. Fitrianie, L. J. M. Rothkrantz. "Dynamic Routing during Disaster Events," In Proceedings of the ISCRAM 2015,Kristiansand, May 24-27.
- [8]. L. J. M. Rothkrantz, "Smart Surveillance Systems, Network Topology in Command and Control:" in *Organization, Operation, and Evolution: Organization, Operation, and Evolution*. IGI Global, 2014.
- [9]. L. J. M. Rothkrantz, "Mitigation using emergent technologies," in *Improving Disaster Resilience and Mitigation-IT Means and Tools*. Springer Netherlands , 2014.
- [10]. H. Kung, J. Hua and C.Chen. "Draught forecast model and framework using wireless sensor network, *Journal of Information Science and Engineering* vol. 22, pp. 751-769, 2006.
- [11]. Arabinda Nanda, ,OmkarPattanaik, Biswajita Mohanty, "Wireless Sensor Network for Prediction of tides using Mamdani Fuzzy Inference System", in *International Journal of Computer Information systems*, Vol. 1, Issue 2, 2010.
- [12]. T. Benjamins, L. J. M. Rothkrantz."Interactive Simulation in crisis management," in Proceedings of the 4th International Conference on Information Systems for Crisis Response and Management, Delft, ISCRAM, pp.571-580, 2007.
- [13]. M. Hendriks, L. J. M. Rothkrantz, T. J. Uffink. "A serious game concerning triage with use of an intelligent tutoring system," in *C Games 2008*. University of Wolverhampton; 2008. pp. 38-42.
- [14]. E. R Musaloiy, ATerzis K. Szlaveez, A Szalay, J. Cogan, and J. Gray. "Life under your feet: A wireless soil ecology sensor networks", 2006.
- [15]. I. Lefter, L. Rothkrantz, D. A. Van Leeuwen, P.Wiggers. "Automatic stress detection in emergency (telephone) calls." *International Journal of Intelligent Defence Support Systems*, vol.4 Issue 2, pp.148-168, 2011.
- [16]. Arabinda Nanda, BanamaliDinda, Ramakanta Rath, Sonali Pradhan, "Wireless Sensor Network For Super Cyclone Prediction Usingartificial Neural Network" *Asian Journal Of Computer Science And Information Technology* vol11, Issue 2, pp 30-33, 2011.
- [17]. Ahmed, N A.K Azad, Mahmudur Rahman Khan, Ahsan Habib, Shuvahish Ghosh, Sabiha Shahid, Shona Bondhu, "A Cloud Based System to Handle Flash Flood, in International Conference on Networking System and Security(NSysS), Bangladesh, pp. 1-7, 2016.
- [18]. Ashok V. Janarthanan, Mohanasundaram R., Certain investigation on ec-a algorithm for energy Minimization in multiprocessor system, *Journal of Advanced Research in Dynamical and Control System* Volume. 09, Issue 06, pp. 204-290, 2017.
- [19]. Baharum M.S., Awang and Baba N.H., "Flood Monitoring System (MyFMS), IEEE International Conference on System Engineering and Technology (ICSET), Malaysia, pp. 204-208, 2011.
- [20]. Danny Hughes, Phil Greenwood, Gordon Blair, Geoff Coulson, Florian Pappenberger, Paul Smith and Keith Beven, *An Intelligent and Warning System*, vol. 05, No. 02, pp. 123-135, 2006.
- [21]. Elizabeth Basha, Danie Rus, (2007), Design of Early Warning Flood Detection System for Developing Countries, in International Conference on Information and Communication Technologies and Development, Bangalore, India, pp. 1-10.
- [22]. Fateen Atiqah Mastor, Izzatdin A Aziz, Nornazatul Natrah Ismail, Mazlina Mehat, Nazleeni Haron, Ade Wahyu, Conceptual Design of Pre-Flood Warning System Based on User Mobility, *International Symposium on Mathematical Sciences and Computing Research (iSMSC)*, Malaysia, pp. 132-137, 2015.
- [23]. Ouychai Intharasombat, Paween Khoenkaw, A Low-Cost Flash Flood Monitoring System, 7th International Conference on Information Technology and Electrical Engineering (ICITEE), Chiang Mai Thailand, pp. 476-479, 2015.
- [24]. Seal, V., Raha, A., Maity, S., Mitra, S. k., Mukherjee, A. and Naskar, M. K. (2012), A Simple Flood Forecasting Scheme Using Wireless Sensor Networks, *International Journal of Adhoc Sensor & Ubiquitous Computing*, Volume. 3, Issue. 01, pp. 45-60.
- [25]. Sakib, SN Tanjea Ane, An intelligent flood monitoring system for Bangladesh using wireless sensor network, 5th International Conference on Information, Electronics and Vision(ICIEV), 2016, pp. 979-984.
- [26]. Windarto, J., Flood Early Warning System develop at Garang River Semarang using Information Technology base on SMS and Web, *International Journal of Geomatics and Geosciences*, Vol. 01, No. 01, 2010, pp35-43.
- [27]. Y. Hashim, "A Review on Transistors in Nano Dimentions" *International Journal of Engineering Technology and Sciences (IJETS)*, Vol. 4, no. 1, pp. 8-18, 2015.
- [28]. Y. Hashim, "Optimization of channel length nano-scale SiNWT based SRAM cell", *AIP Conference Proceeding*, Volume. 1774, Issue 1, pp,050020 -1-7, 2016.
- [29]. A. Ali, M. AI-Sound, E. Abdallah, S. Addallah, "Water pumping system with PLC and frequency control", *Jordan Journal of Mechanical and Industrial Engineering*, Volume. 3, Issue. 3, pp. 216-220, 2009.
- [30]. R. Bayindir, Y. Cetinceviz, "A Water pumping control system with a programmable logic controller (PLC) and industrial wireless modules for industrial plants-An experimental setup", *ISA Transactions*, Volume. 50, Issue 2, pp. 321-328, 2011.
- [31]. S. McCarthy, C. Viavattene, J. Sheehan, C. Green, "Compensatory approaches and engagement techniques to gain flood storage in England and Wales, *Journal of Flood Risk Management*, 2018.